

Writing an article entitled:

Use of a “Capacitor – Resistor Circuit” to Measure Small Periods of Time.

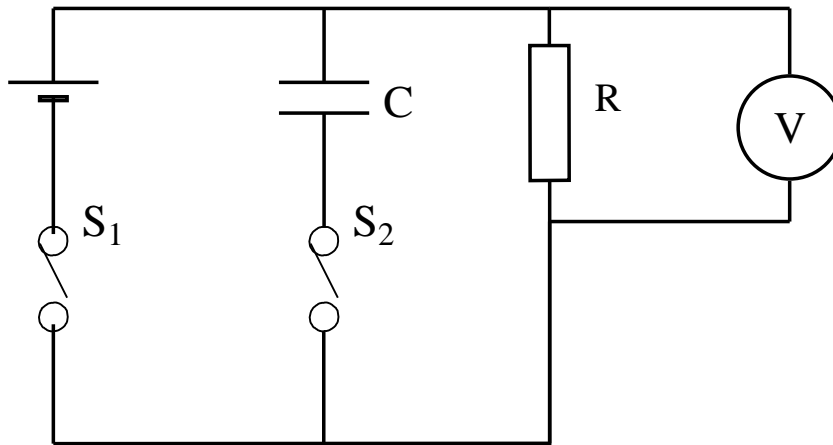

The circuit above shows how two switches, a battery, a capacitor, a resistor and a voltmeter are connected together.

Answer the questions below by writing a small article that may include diagrams and graphs. It is important that you do not write an answer to each part as you might in an examination. You should attempt to write the article so that an intelligent person can obtain the answers from it.

You may give values to the components if it helps you to describe what happens (for example the emf of the battery is 6.0 V with zero internal resistance).

1. What will be the reading on the voltmeter when both switches are closed?
2. What happens to the voltmeter reading when switch S_1 is opened and switch S_2 remains closed?
3. What happens to the voltmeter reading when S_2 is opened, so that both switches are open?
4. How could you obtain the length of time between the opening of S_1 and the opening of the switch S_2 using the voltmeter readings in parts 1 and 3 above? (Assume that the values of C and R are known.)
5. Explain fully how this circuit can be used to measure the **time** it takes a ball bearing to fall from an electromagnet to opening a trap door in the experiment to measure the acceleration due to gravity by free-fall. (An incomplete diagram is shown below.)

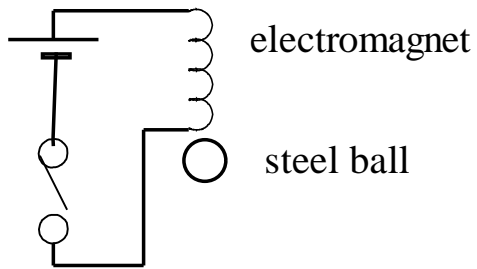

Please note that this is an incomplete diagram.

Fuller diagrams may be found in various textbooks.

The diagram you have to draw must resemble the “CR-circuit diagram” shown at the top.

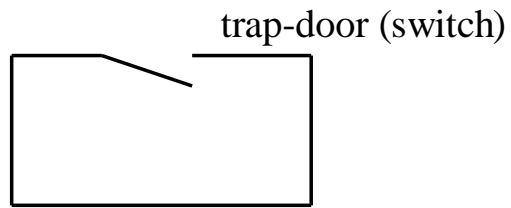

You will have to complete this task practically in three weeks time, so it is important that you understand the principles of the experiment beforehand.